

high quality
performance

F-TH[®]

FLEXO PLATE DRYER



Dryer- with 6 drawers - Model: PRO-IV-D

- ✓ 7" Graphic Touch Screen
- ✓ Uniform temperature distribution through the separate drying chambers
- ✓ Easy designed operation panel displays all necessary times and settings, e.g. individual digital timer and countdown facility for each drying drawer
- ✓ Highly efficient exhaust air extraction system with safety shut-down facility prevents solvent vapours from escaping
- ✓ Excellent productivity and consistency high powered heating output of 4 kW to quickly achieve the necessary operating temperature
- ✓ Excellent build quality offers a long service life
- ✓ Low energy consumption due to good heat insulation
- ✓ Ecologically friendly and economical
- ✓ Easy to operate via display
- ✓ Six drying drawers with wide opening
- ✓ Programmable digital timer for each drawer to allow the input of different drying times.



REVVIS PRO-IV - Dryer with Light-Finisher

Dryer- with 6 drawers



REVVIS PRO-IV - Dryer with Light-Finisher

Maximum Plate Size: 1320X2032 mm
Power Supply: 400V AC 3Phase N-PE

Dryer and Light-Finisher + Post Exposure Combination

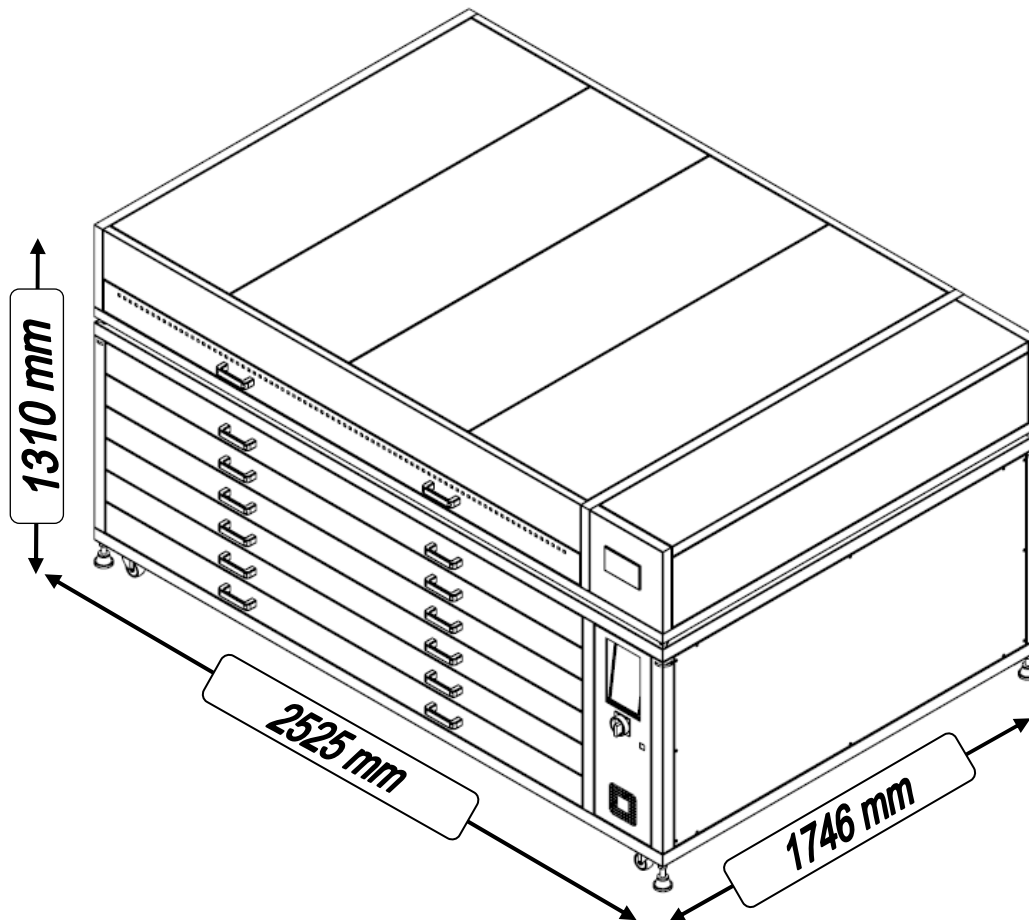

Dimensions and weight for both units:

- Approx. Weight: 1000 kg
- Approx. Crate Dimension: 257X179X150 mm
- Approx. Gross Weight: 1300
- Power Supply: 400V AC 3Phase N-PE



Flexo-Technic Handels GmbH

Phone: 0049-6181-6709055
Mobile: 0049-163-3722340
E-Mail: info@fexotechnic.de
Web: www.flexo-technic.de
www.stapelwender.biz